

# WALLS

The walls of a building serve several important functions: They define the spaces within the building to provide privacy and zoning, and they enclose the building itself, keeping the weather out and the heat or cold in. Walls provide the vertical structure that supports the upper floors and roof of the building, and the lateral structure that stiffens the building. Walls also encase the mechanical systems (electrical wiring, plumbing, and heating). To incorporate all of this within a 4-in. or 6-in. deep wood-framed panel is quite an achievement, so numerous decisions need to be made in the course of designing a wall system for a wood-frame building. There are two preliminary decisions to make that establish the framework for the remaining decisions.

## WALL THICKNESS

Should the walls be framed with 2x4s or 2x6s? The 2x6 wall has become increasingly popular in recent years, primarily because it provides more space for insulation and allows for other minor energy-saving advantages (such as the ability to run electricity in a notched base, as shown in 73A). These advantages all come at some cost. A 2x6 wall with studs spaced 24 in. o.c. (the maximum spacing allowed by codes) uses about 20% more material for studs and plates than a 2x4 wall with studs with a code-allowed spacing of 16 in. o.c. On the outside, the sheathing has to be ½ in. thick (¼ in. thicker than sheathing on a standard 2x4 wall). Inside, the drywall also has to be ½ in. thicker to span the 24-in. spacing between 2x6 studs. Thicker insulation costs more too. So, overall, 2x6 framing makes a superior wall, but one that costs more. Framing the exterior walls with 2x6s and interior walls with 2x4s is a typical combination when the energy-efficient 2x6 wall is selected. Stud spacing of 2x4 and 2x6 walls may vary with loading, lumber grades, and finish materials; in this book, however, studs are assumed to be 16 in. o.c. in 2x4 walls and 24 in. o.c. in 2x6 walls unless noted otherwise.

## FRAMING STYLE

Should the walls be built using platform framing or balloon framing? Balloon framing, with studs continuous from mudsill to top plate and continuous between floors, was developed in the 1840s and is the antecedent of the framed wall. In recent years, balloon framing has been almost completely superseded by the more labor-efficient and fire-resistant platform frame construction, with studs extending only between floors. There are still situations, however, where a variation of the balloon frame system is useful. One such situation is where the continuity of studs longer than the normal ceiling height is essential to the strength of a wall. Examples include parapet walls and eave (side) walls that must resist the lateral thrust of a vaulted roof (as in a 1½-story building).

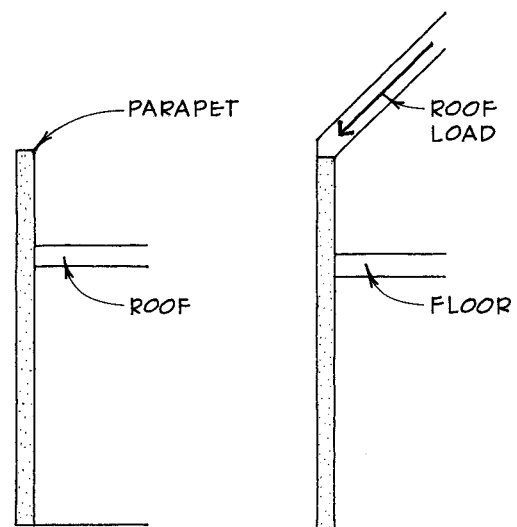

Balloon-framed gable-end walls also provide increased stability in high-wind areas (see 160).

Another reason for using balloon framing is to minimize the effects of shrinkage that occurs across the grain of joists in a platform-framed building. This could be important with continuous stucco siding that spans two floors without a control joint, or in a multiple-story hybrid building system where the floors in the balloon-framed part would not shrink equally with the floors in the platform-framed part.

## DESIGNING A WALL SYSTEM

Once the stud size and spacing and the framing system have been selected, it is time to consider how to brace the building to resist the forces of wind, earthquakes, and eccentric loading. Will diagonal bracing be adequate, or should the building be braced with structural sheathing and/or shear walls? This question is best answered in the context of the design of the building as a whole, considering the other materials that complete the wall system. How is the wall to be insulated? Where are the openings in the wall for doors and windows? Will there be an air-infiltration barrier? What material will be used for the exterior finish? The details relating to these issues are addressed in this chapter, along with some suggestions for their appropriate use. How these various details are assembled into a complete wall system depends on local climate, codes, tradition, and the talent of the designer.

## SIZING HEADERS

Header size depends on wood species and grade, loading, header design, and rough-opening span. Following is a rule of thumb for sizing a common header type, the 4x header (see 68B):

For a single-story building with a 30-lb. live load on the roof and 2x4 bearing walls, the span in feet of the rough opening should equal the depth (nominal) in inches of a 4x header. For example, openings up to 4 ft. wide require a 4x4 header.

## ABOUT THE DRAWINGS

Construction terms vary regionally, and the names for the components that frame wall openings (see 68A) are the least cast in stone. Studs called “trimmer studs” in one locality are called “jack studs” in another; and the bottom plate may go by either “bottom plate” or “sole plate.” Consult local builders and architects for common usage.

For clarity, insulation is not generally shown in the exterior walls except in the insulation section (120–125).

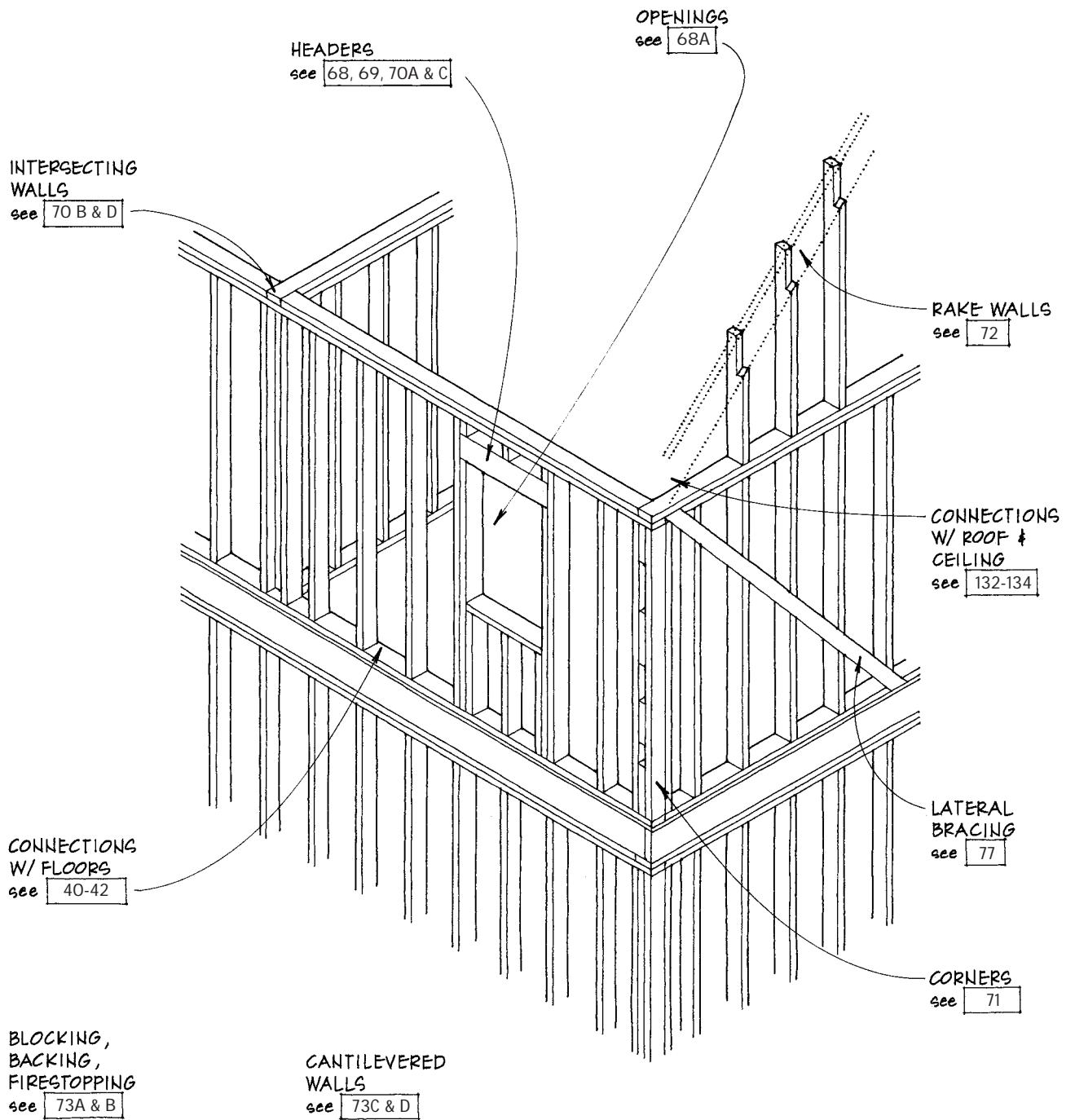

RESOURCE - EFFICIENT  
ADVANCED FRAMING  
see 74

NOTE:  
IN THIS CHAPTER ALL 2x4 WALLS ARE SHOWN  
WITH STUDS @ 16 IN. O.C.; ALL 2x6 WALLS ARE  
SHOWN WITH STUDS @ 24 IN. O.C.; UNLABELED  
WALLS MAY BE EITHER 2x4 OR 2x6.



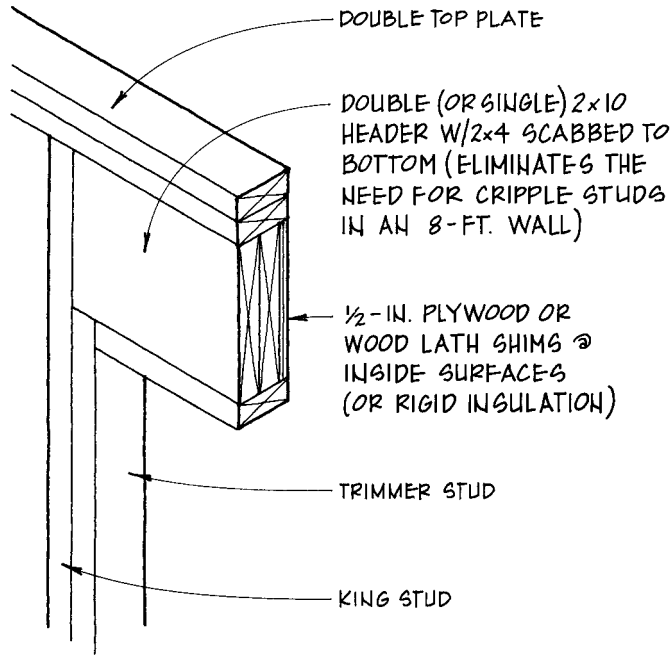

**A** 2x10 HEADER  
2x4 BEARING WALL

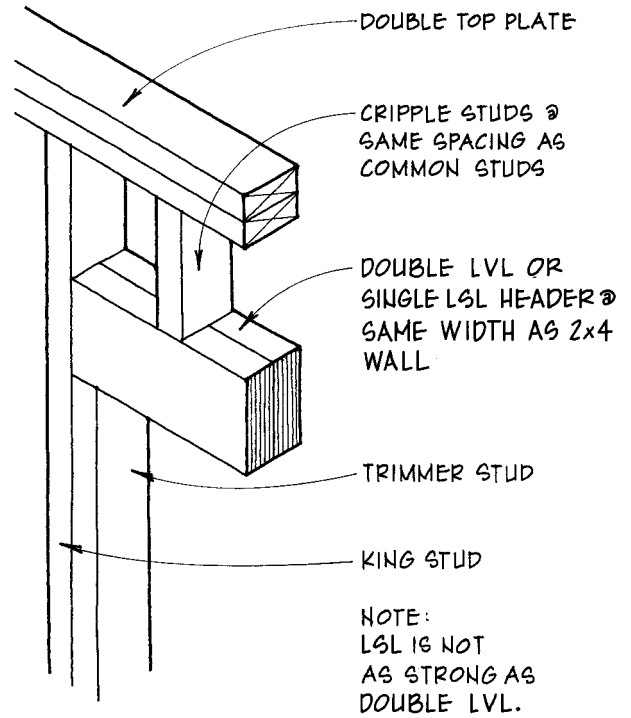

**B** DOUBLE LVL OR LSL HEADER  
2x4 BEARING WALL

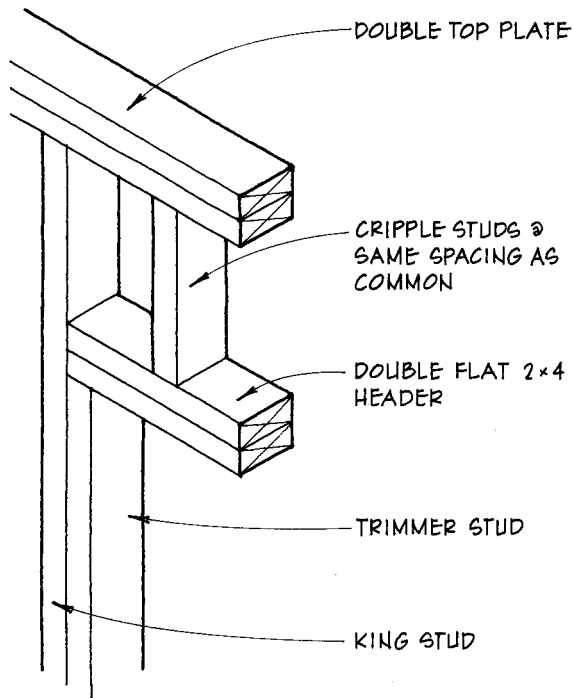

**C** FLAT 2x4 HEADER  
2x4 PARTITION WALL

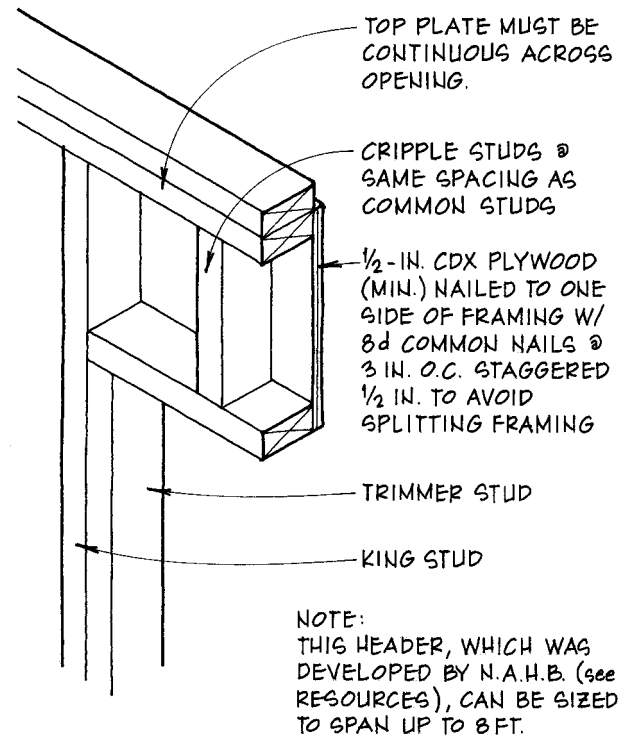

**D** OPEN-BOX PLYWOOD HEADER  
2x4 BEARING WALL

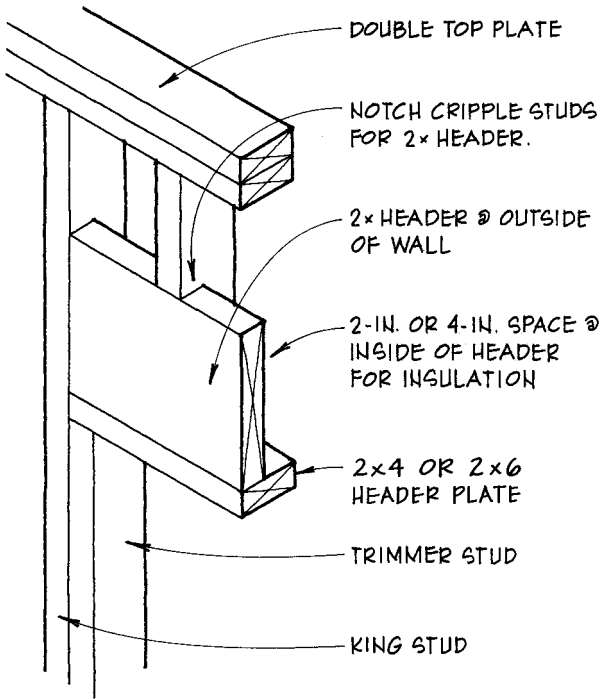

**A** **INSULATED HEADER**  
2x4 OR 2x6 EXTERIOR WALL

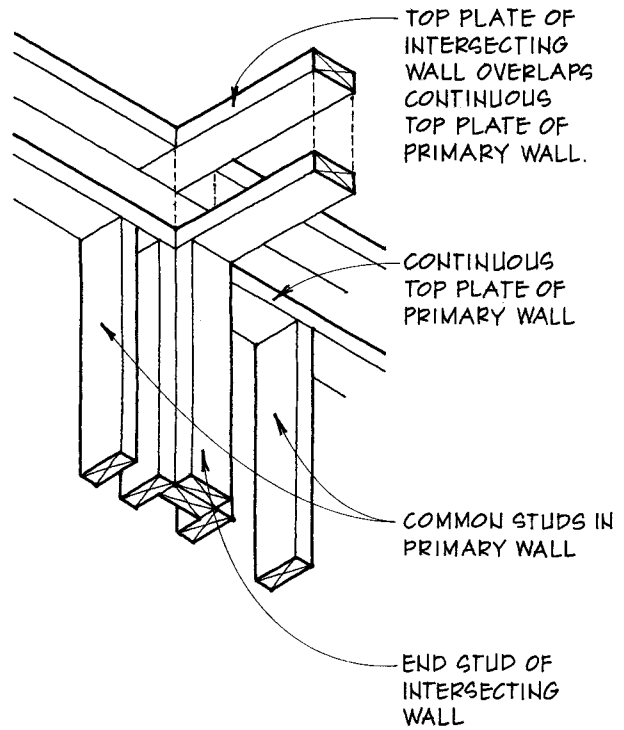

**B** **INTERSECTING 2x WALLS**  
@ DOUBLE TOP PLATE

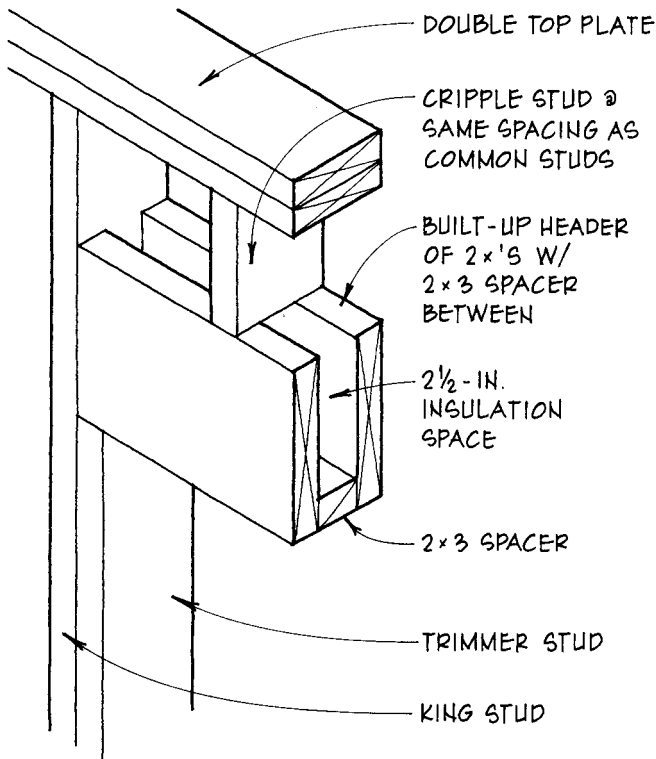

**C** **INSULATED DOUBLE 2x HEADER**  
2x6 BEARING WALL/ALTERNATIVE DETAIL

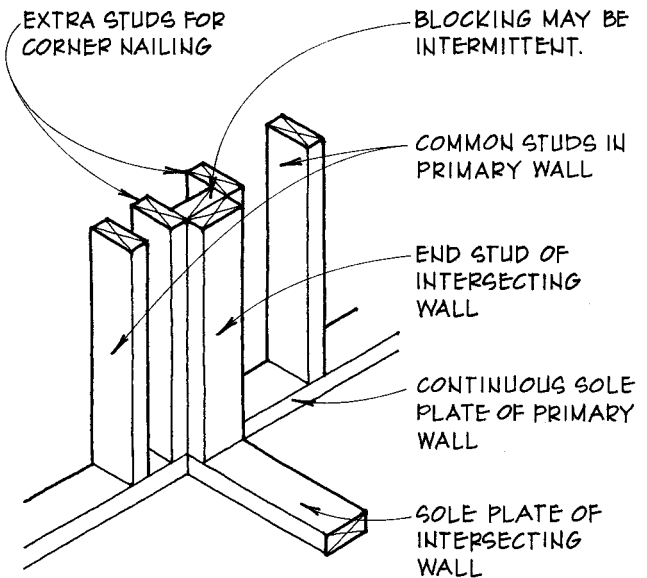

NOTE:  
INSULATE CAVITY BEHIND INTERSECTING WALL  
BEFORE SHEATHING IS APPLIED IF PRIMARY

**D** **INTERSECTING 2x WALLS**  
@ SOLE PLATE

DOUBLE TOP PLATE OVERLAPS @ CORNERS TO LOCK TWO WALLS TOGETHER.

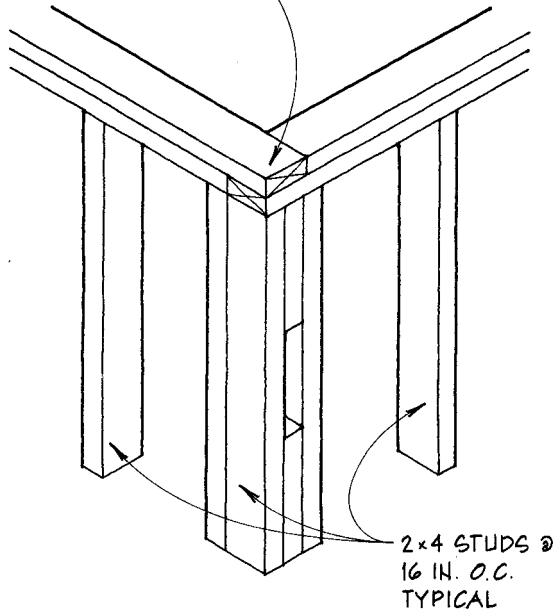

**A** 2x4 CORNER @ DOUBLE TOP PLATE

DOUBLE TOP PLATE OVERLAPS @ CORNERS, LOCKING TWO WALLS TOGETHER.

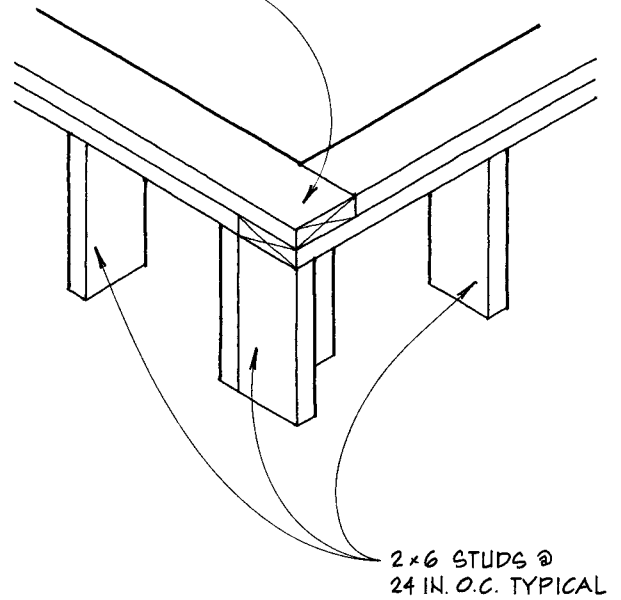

**B** 2x6 CORNER @ DOUBLE TOP PLATE

CORNER STUDS BUILT UP W/ 2x4 BLOCKING BETWEEN PROVIDES NAILING @ INSIDE CORNER.

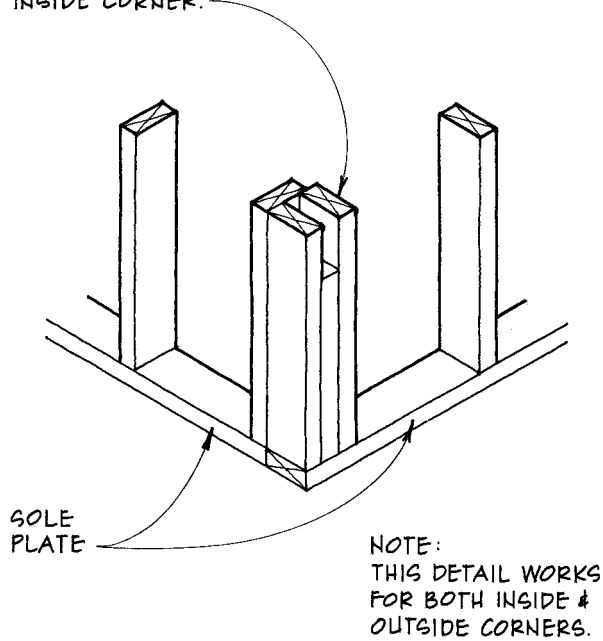

**C** 2x4 CORNER @ SOLE PLATE

EXTRA STUD ADDED PERPENDICULAR TO CORNER STUD PROVIDES NAILING @ INSIDE CORNER & ALLOWS SPACE FOR 4-IN. THICK INSULATION @ CORNER.

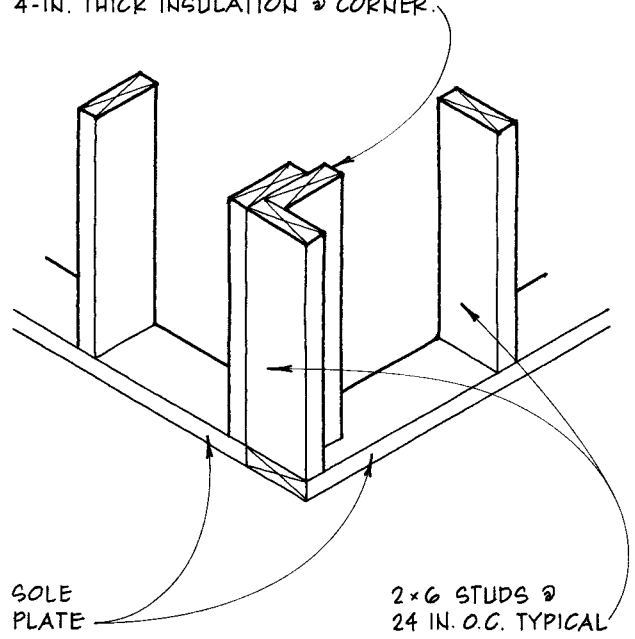

**D** 2x6 CORNER @ SOLE PLATE

A wall that extends to a sloped roof or ceiling is called a rake wall and may be built one of two ways:

**Platform framing**—Platform framing is commonly the method of choice when a horizontal structural element such as a floor or ceiling ties the structure together at the level of the top plate or when the top plate itself is short enough to provide the necessary lateral strength (see 72B).

**Balloon framing**—Balloon framing allows for ease of construction and economy of material and stabilizes a tall wall where there is no horizontal structure at the level of the top plate or where lateral forces are extreme, such as in high-wind areas (see 72C).

For details of rake walls with truss-framed roofs, see 157.

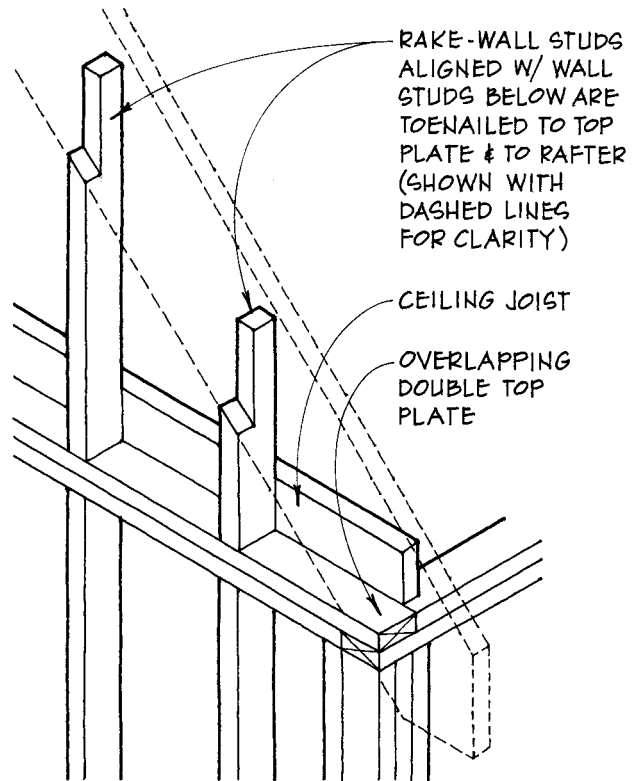

**B** RAKE WALL PLATFORM FRAMING

**A** RAKE WALL NOTES

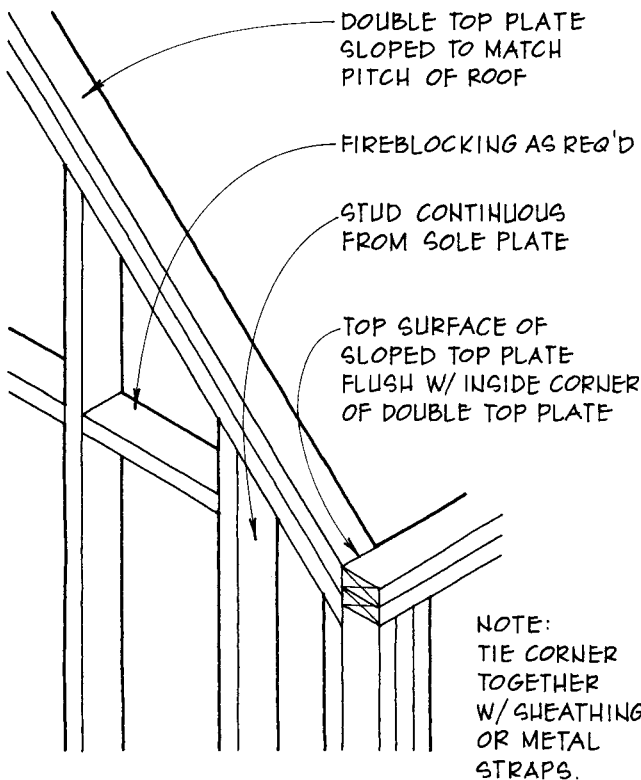

**C** RAKE WALL BALLOON FRAMING

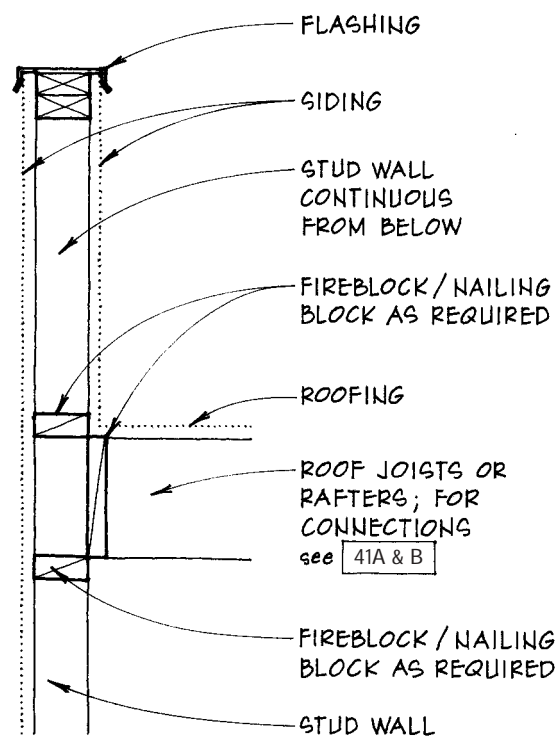

**D** PARAPET WALL FRAMING ROOF JOISTS SHOWN ⊥ TO WALL



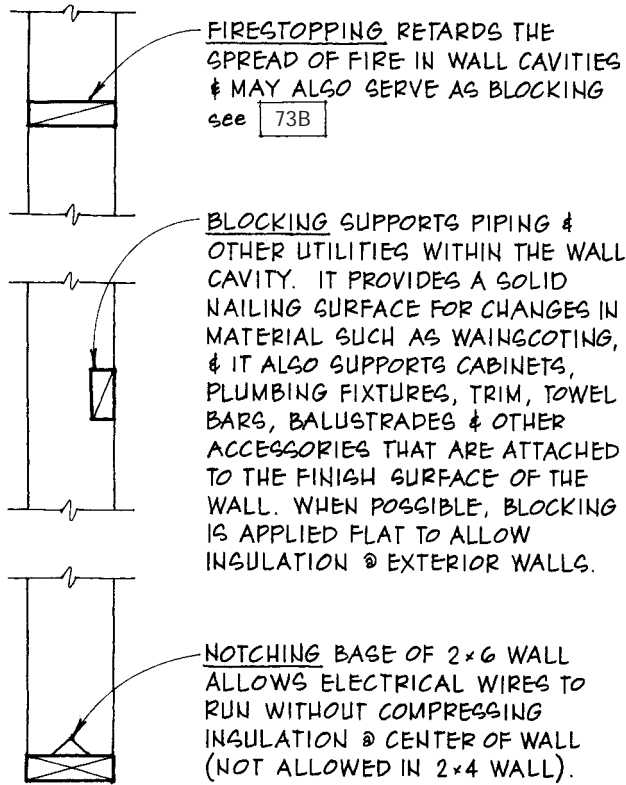

**A** BLOCKING & NOTCHING

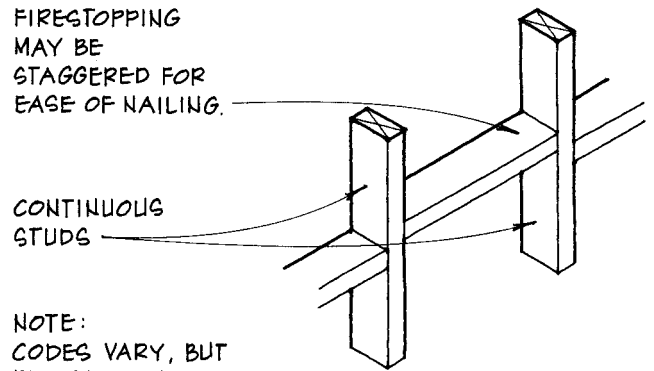

NOTE:  
CODES VARY, BUT FIRESTOPPING IS USUALLY REQUIRED: AT STAIRS ALONGSIDE THE STRINGERS; BETWEEN FLOORS & BETWEEN THE TOP FLOOR AND THE ATTIC IN BALLOON-FRAME BUILDINGS (THE PLATES IN PLATFORM-FRAME BUILDINGS AUTOMATICALLY PROVIDE FIREBLOCKING BETWEEN FLOORS); BETWEEN WALL CAVITIES & CONCEALED HORIZONTAL SPACES SUCH AS SOFFITS & DROP CEILINGS; IN TALL WALLS EVERY 10 FT. VERTICALLY.

FIRESTOPPING IS USUALLY 2x FRAMING LUMBER BUT CAN ALSO BE OTHER MATERIALS SUCH AS LAYERS OF PLYWOOD OR GYPSUM WALLBOARD WHEN APPROVED BY LOCAL CODES.

**B** FIRESTOPPING

IT IS OCCASIONALLY DIFFICULT OR IMPOSSIBLE TO CANTILEVER THE FLOOR FRAMING TO SUPPORT A PROJECTION FROM THE BUILDING. WHERE LOADS ARE NOT GREAT, IT IS POSSIBLE TO SUPPORT THE PROJECTION WITH CANTILEVERED WALLS.

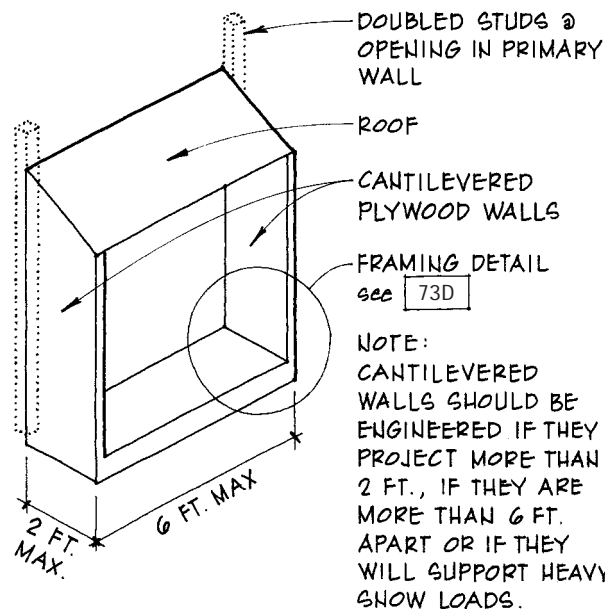

**C** CANTILEVERED WALLS

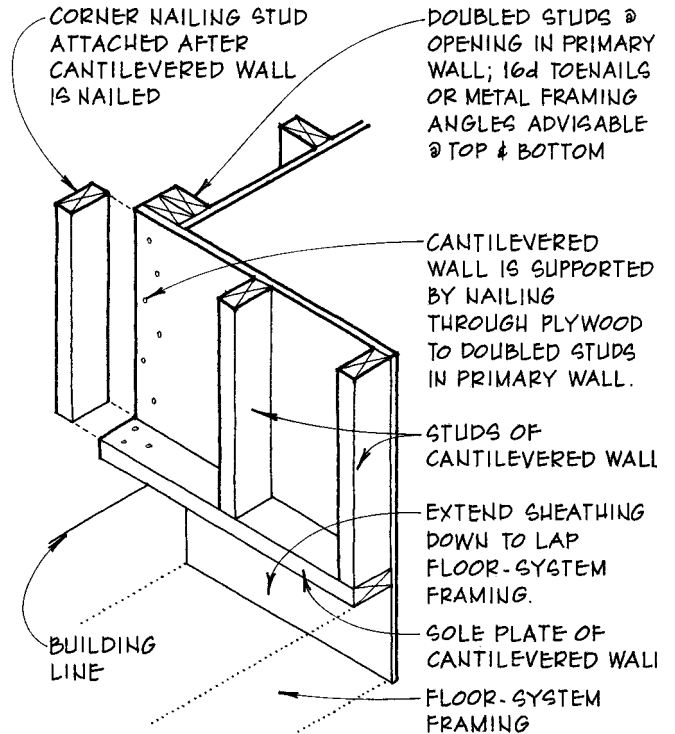

**D** CANTILEVERED-WALL FRAMING  
DETAIL @ BASE

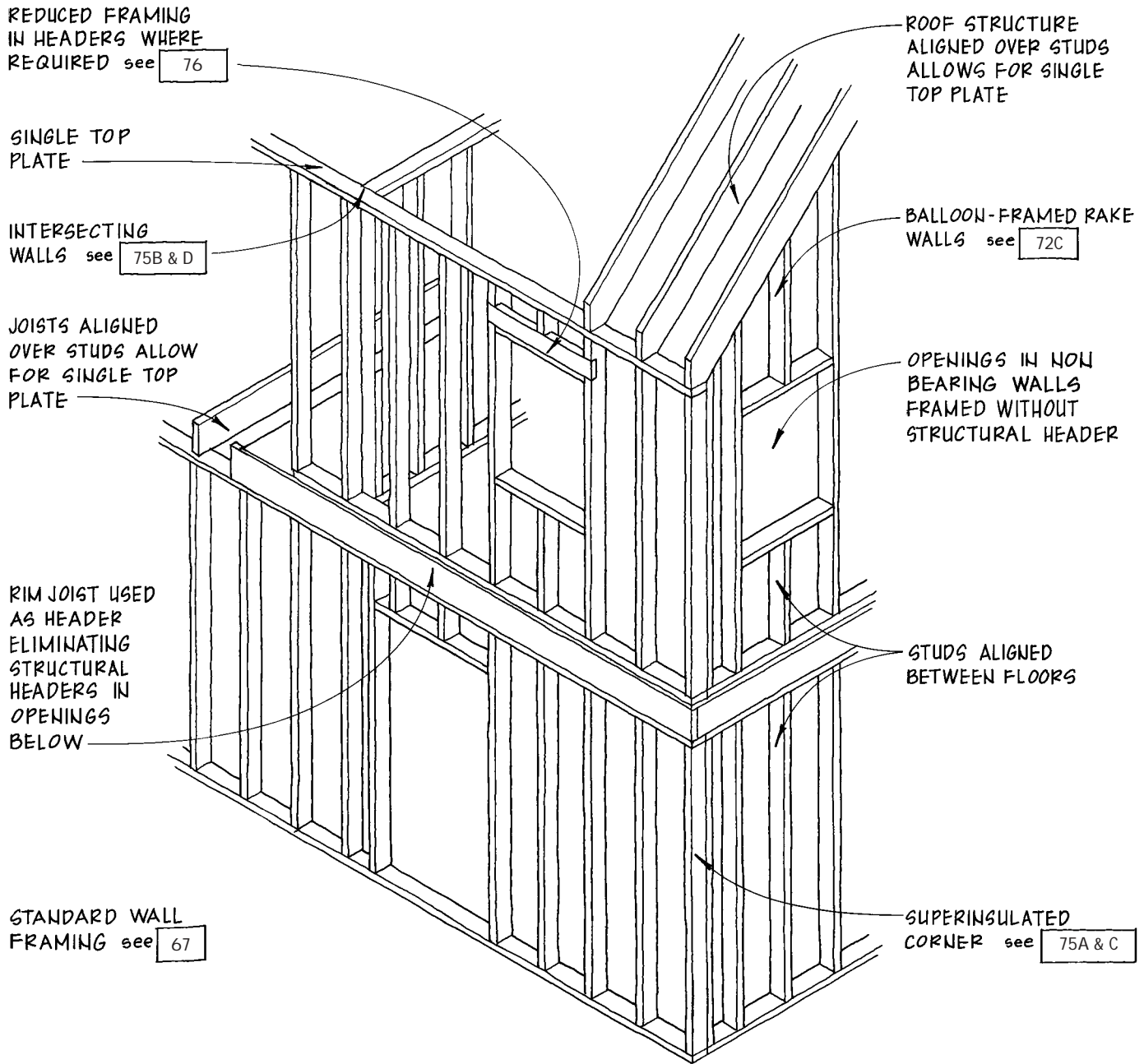

**Advanced framing**—Advanced framing minimizes the amount of framing that spans from the interior to the exterior of a wall, thus lowering the effect of thermal bridging. By limiting the amount of framing, more volume in the wall can be occupied by insulation, which increases thermal performance of the overall assembly. Advanced framing alone can

increase the thermal performance of framed walls by only about 7%, but, given that it uses less material than standard framing and actually helps to conserve a precious resource, it should be considered for every framed building. Details of advanced framing are illustrated on 75–76.

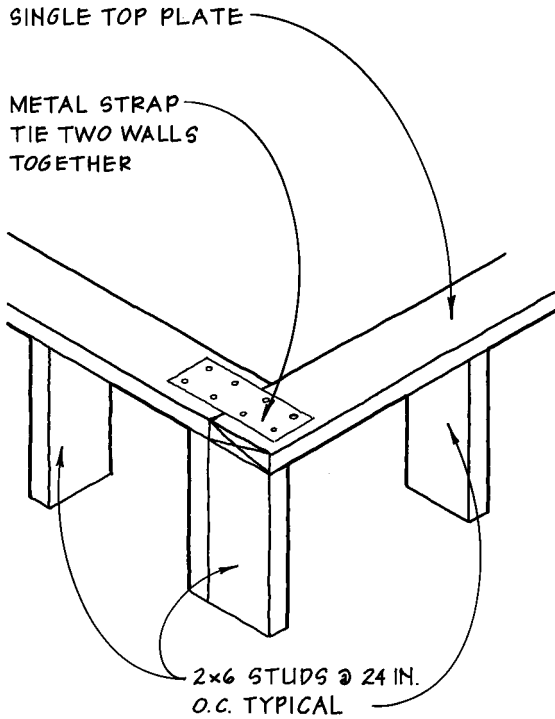

**A** SUPERINSULATED 2x6 CORNER  
OUTSIDE CORNER ONLY @ TOP PLATE

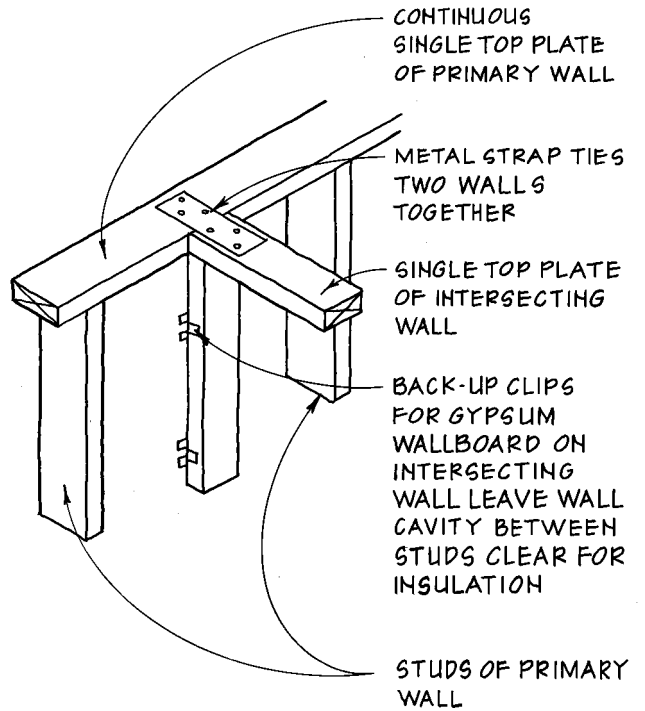

**B** INTERSECTING 2x WALLS  
@ TOP PLATE

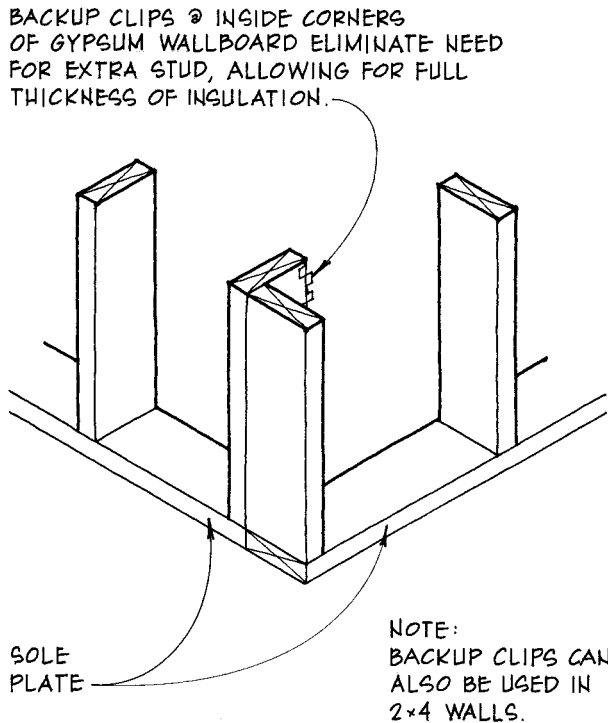

**C** SUPERINSULATED 2x6 CORNER  
OUTSIDE CORNER ONLY @ SOLE PLATE

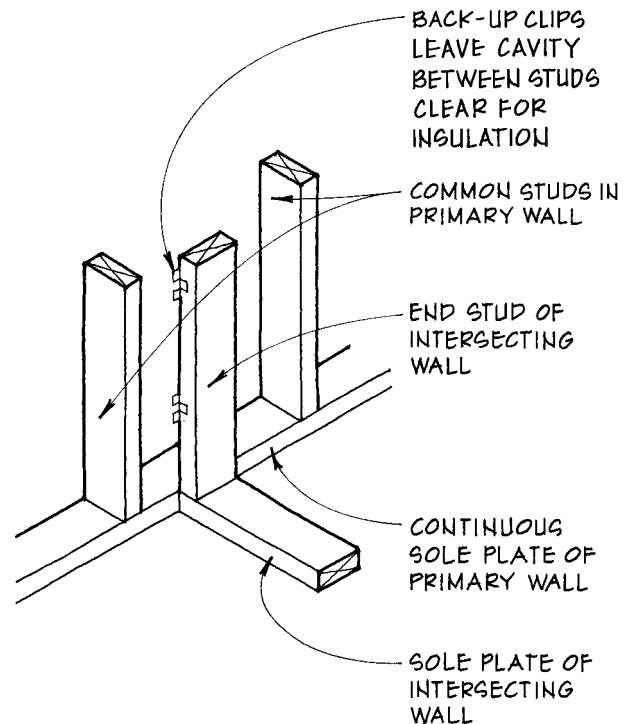

**D** INTERSECTING 2x WALLS  
@ SOLE PLATE

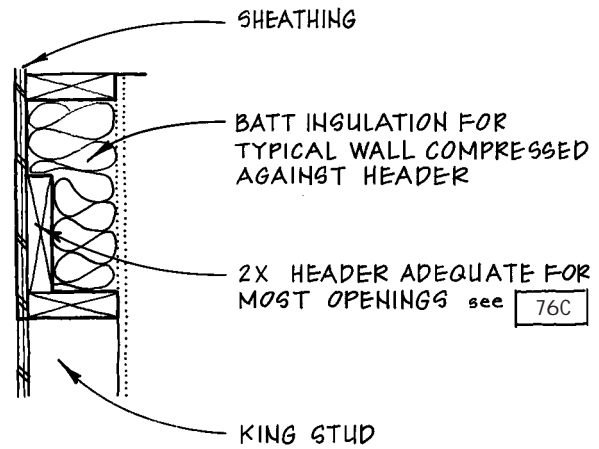
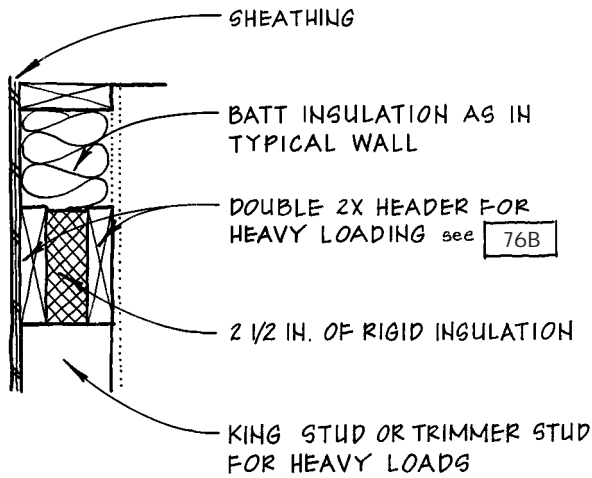

The goal when designing an energy-efficient header is to allow for the most insulation while providing for nailing at both the exterior and interior of the opening.

When a structural header is required over an opening in an exterior wall, the header itself occupies space that could otherwise be filled with insulation. Because a deep (tall) header is more effective structurally than a wide one, the header does not usually have to fill the entire width of the wall. In fact, the taller and thinner the header, the more space there

will be for insulation. The headers illustrated on this page provide both structure and space for insulation. The box header (see 69D) also provides space for insulation because it uses sheathing as structure.

The elimination of the trimmer studs that usually support a header at its ends also allows for more insulation in the wall. The header can usually be supported by the king stud as illustrated in the two examples below. (Backing may need to be added to the king studs when wide casings are used.)

**A** SUPERINSULATED HEADERS  
GENERAL

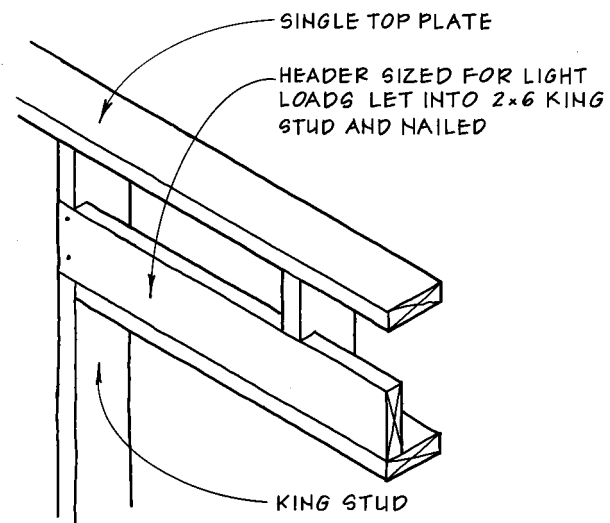
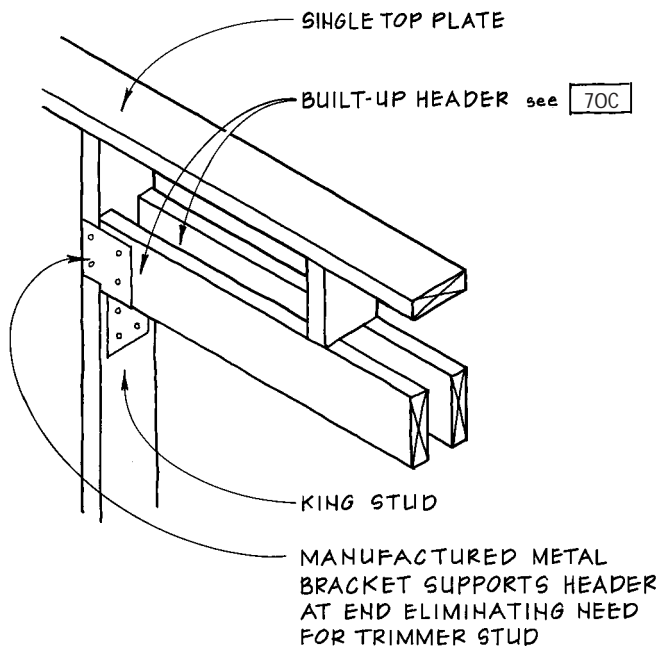

**B** SUPERINSULATED HEADER  
RELATIVELY HEAVY LOADS

**C** SUPERINSULATED HEADER  
RELATIVELY LIGHT LOADS